



# RT 632 (6V3.2Ah)

RT632 is a general purpose battery with 5 years floating design life, meet with IEC, JIS standard. With heavy duty grid, thickness plates, special additives, RT series battery have long and reliable standby service life.



## Specification

Cells Per Unit	3
Voltage Per Unit	6
Capacity	3.2Ah@20hr-rate to 1.75V per cell @25°C
Weight	Approx. 0.65 Kg
Max. Discharge Current	32 A (5 sec)
Internal Resistance	Approx. 25 mΩ
Operating Temperature Range	Discharge: -20°C~60°C Charge: 0°C~50°C Storage: -20°C~60°C
Normal Operating Temperature Range	25°C±5°C
Float charging Voltage	6.85 to 6.95 VDC/unit Average at 25°C
Recommended Maximum Charging Current Limit	0.96 A
Equalization and Cycle Service	7.3 to 7.4 VDC/unit Average at 25°C
Self Discharge	RITAR Valve Regulated Lead Acid (VRLA) batteries can be stored for more than 6 months at 25°C. Self-discharge ratio less than 3% per month at 25°C. Please charge batteries before using.
Terminal	Faston Tab 187(F1)
Container Material	A.B.S. (UL94-HB), Flammability resistance of UL94-V2 can be available upon request.

MH28539  
G4M20206-0910-E-16  
ISO9001:2000 Certificate

## Dimensions

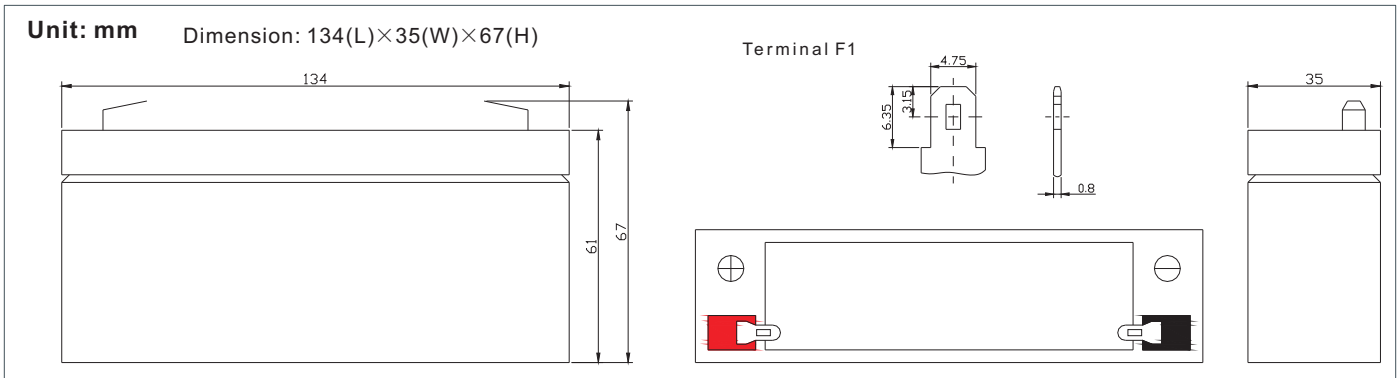

### Constant Current Discharge Characteristics : A(25°C)

F.V/Time	5MIN	10MIN	15MIN	30MIN	1HR	2HR	3HR	4HR	5HR	8HR	10HR	20HR
4.80V	13.01	8.531	6.687	3.754	2.230	1.285	0.873	0.699	0.580	0.369	0.320	0.180
5.00V	12.54	8.318	6.473	3.706	2.170	1.259	0.857	0.689	0.570	0.368	0.317	0.173
5.10V	11.80	7.906	6.293	3.649	2.149	1.245	0.849	0.682	0.564	0.365	0.312	0.170
5.25V	10.61	7.393	5.935	3.548	2.107	1.229	0.842	0.676	0.557	0.361	0.310	0.165
5.40V	9.508	6.894	5.600	3.431	2.069	1.219	0.832	0.672	0.551	0.360	0.305	0.155
5.55V	8.318	6.321	5.166	3.301	2.013	1.170	0.816	0.666	0.546	0.357	0.300	0.153

### Constant Power Discharge Characteristics : W(25°C)

F.V/Time	5MIN	10MIN	15MIN	30MIN	1HR	2HR	3HR	4HR	5HR	8HR	10HR	20HR
4.80V	68.44	45.37	35.79	21.48	12.95	7.493	5.102	4.133	3.434	2.212	1.916	1.076
5.00V	66.66	44.43	35.28	21.26	12.76	7.429	5.092	4.123	3.416	2.204	1.898	1.038
5.10V	63.41	42.67	34.81	21.08	12.67	7.382	5.073	4.089	3.383	2.187	1.880	1.018
5.25V	57.87	40.91	33.00	20.65	12.49	7.323	5.052	4.052	3.343	2.169	1.860	0.990
5.40V	52.21	38.27	31.18	20.16	12.29	7.262	4.993	4.037	3.308	2.159	1.832	0.932
5.55V	46.04	35.63	29.37	19.60	12.06	7.011	4.895	3.996	3.277	2.144	1.805	0.917

All mentioned values are average values.

**Effect of temperature on long term float life**

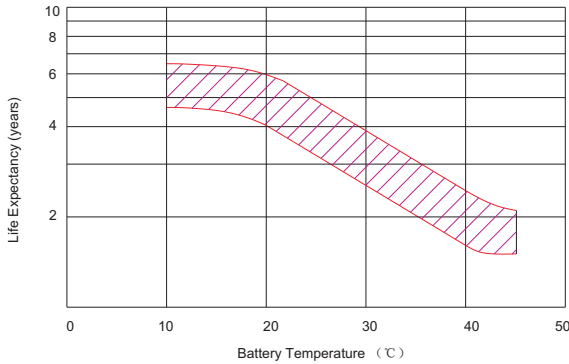

**Storage characteristic**

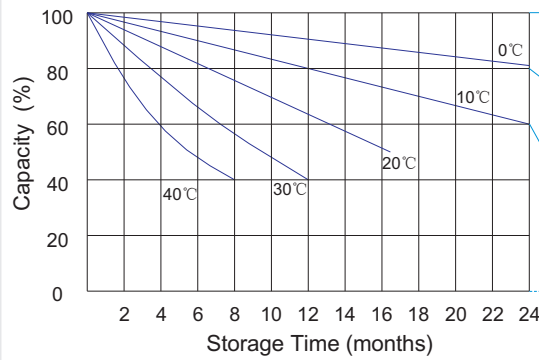

Supplementary charge required (Carry out supplementary charge before use if 100% capacity is requires)

Supplementary charge required before use. This supplementary charge will help to recover the capacity and should be made as early as possible.

Supplementary charge may often fail to recover the capacity. The battery should never be left standing till this state is reached

Supplementary charge and storage guidelines

**Charge characteristic Curve for standby use**

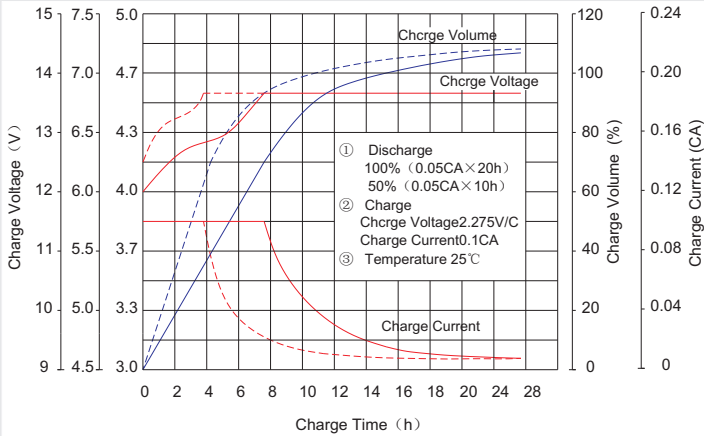

**Discharge characteristic Curve**

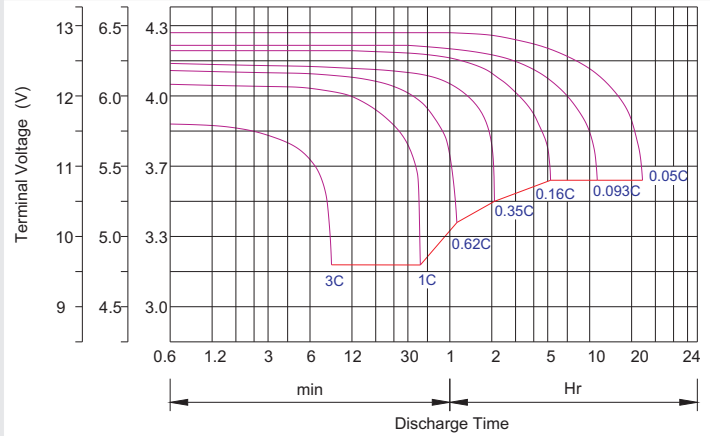

## Capacity Factors With Different Temperature

Battery Type		-20°C	-10°C	0°C	5°C	10°C	20°C	25°C	30°C	40°C	45°C
GEL Battery	6V&12V	50%	70%	83%	85%	90%	98%	100%	102%	104%	105%
	2V	60%	75%	85%	88%	92%	99%	100%	103%	105%	106%
AGM Battery	6V&12V	46%	66%	76%	83%	90%	98%	100%	103%	107%	109%
	2V	55%	70%	80%	85%	92%	99%	100%	104%	108%	110%

## Discharge Current VS. Discharge Current Voltage

Final Discharge Voltage V/cell	1.75V	1.70V	1.60V
Discharge Current (A)	(A) ≤ 0.2C	0.2C < (A) < 1.0C	(A) ≥ 1.0C

**Charge the batteries at least once every six months, if they are stored at 25°C.**

Charging Method:

Constant Voltage	-0.2Cx2h+2.4~2.45V/Cellx24h, Max. Current 0.3CA
Constant Current	-0.2Cx2h+0.1CAx12h
Fast	-0.2Cx2h+0.3CAx4.0h

## Maintenance & Cautions

<b>Float Service:</b>
※ Every month, recommend inspection every battery voltage.
※ Every three months, recommend equalization charge for one time.
Equalization charge method:
Discharge: 100% rate capacity discharge.
Charge: Max. current 0.3CA, constant voltage 2.4-2.45V/Cell charge 24h.
※ Effect of temperature on float charge voltage: -3mV/°C/Cell.
※ Length of service life will be directly affected by the number of discharge cycles, depth of discharge, ambient temperature and charging voltage.