



RL 2800 (2V800Ah)

RL 2800 is a general purpose battery with 18 years floating design life. With heavy duty grid, thick plates, special additives, RL series battery maintain very long life time and stable performance.



Specification

Cells Per Unit	1
Voltage Per Unit	2
Capacity	800Ah@10hr-rate to 1.80V per cell @25°C
Weight	Approx.50.0Kg
Max. Discharge Current	3200 A (5 sec)
Internal Resistance	Approx. 0.6 mΩ
Operating Temperature Range	Discharge: -20°C~60°C Charge: 0°C~50°C Storage: -20°C~60°C
Normal Operating Temperature Range	25°C±5°C
Float charging Voltage	2.27 to 2.3 VDC/unit Average at 25°C
Recommended Maximum Charging Current Limit	160 A
Equalization and Cycle Service	2.43 to 2.47 VDC/unit Average at 25°C
Self Discharge	RITAR batteries can be stored for more than 6 months at 25°C. Self-discharge ratio less than 3% per month at 25°C. Please charge batteries before using.
Terminal	Thread insert & Bolt (F10)
Container Material	A.B.S. (UL94-HB), Flammability resistance of UL94-V1 can be available upon request.



MH28539



G4M20206-0910-E-16



ISO9001:2000 Certificate

Dimensions

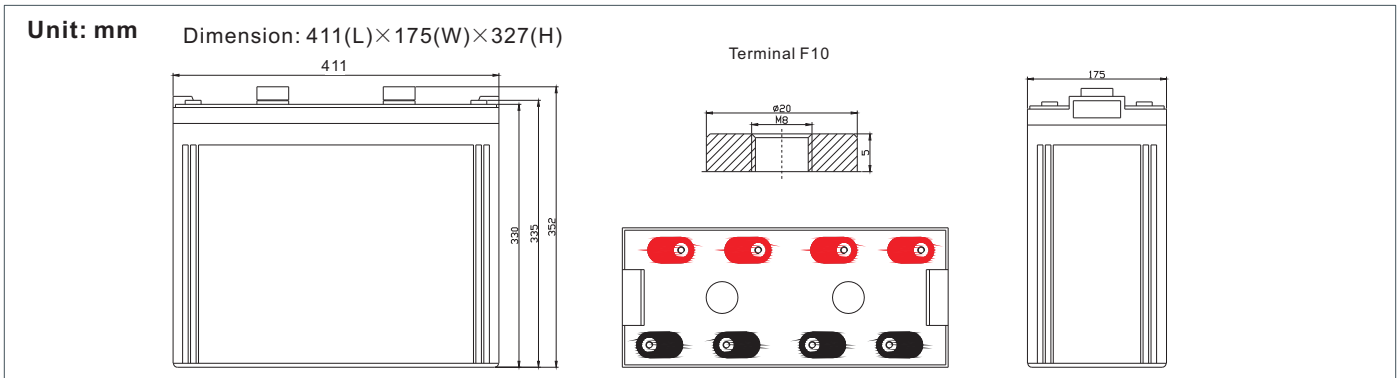

Constant Current Discharge Characteristics : A(25°C)

F.V/Time	15MIN	30MIN	1HR	2HR	3HR	4HR	5HR	6HR	8HR	10HR
1.60V	1086.2	801.0	515.5	306.4	228.2	181.9	153.2	128.7	103.9	86.82
1.65V	1032.8	769.1	493.2	295.3	218.7	175.6	146.8	125.6	99.23	85.32
1.70V	963.1	725.0	483.6	290.5	213.9	174.0	145.2	122.5	97.68	83.77
1.75V	855.0	652.5	445.3	274.5	202.7	164.4	138.9	116.3	94.57	82.22
1.80V	736.0	594.3	419.7	261.7	194.7	162.8	134.1	114.7	93.02	80.67
1.85V	622.4	535.0	387.8	247.4	185.1	150.0	127.7	108.5	88.37	75.22

Constant Power Discharge Characteristics : W(25°C)

F.V/Time	15MIN	30MIN	1HR	2HR	3HR	4HR	5HR	6HR	8HR	10HR
1.60V	1902	1460	943.9	567.7	425.3	341.9	289.6	248.3	197.7	167.6
1.65V	1852	1452	940.6	559.5	417.0	336.8	286.3	245.1	196.0	166.0
1.70V	1749	1374	923.5	551.3	410.6	335.5	283.8	239.4	193.0	163.5
1.75V	1558	1238	850.7	521.9	395.9	318.7	271.8	227.6	186.9	160.8
1.80V	1349	1130	802.2	498.4	379.5	317.2	263.0	224.9	183.9	155.1
1.85V	1150	1018.7	741.5	471.8	361.5	293.8	251.0	213.1	174.7	149.4

All mentioned values are average values.

Effect of temperature on long term float life

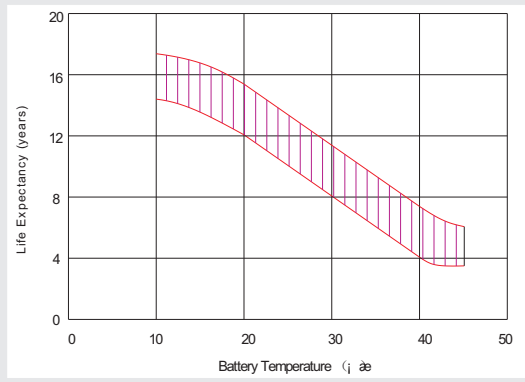

Storage characteristic

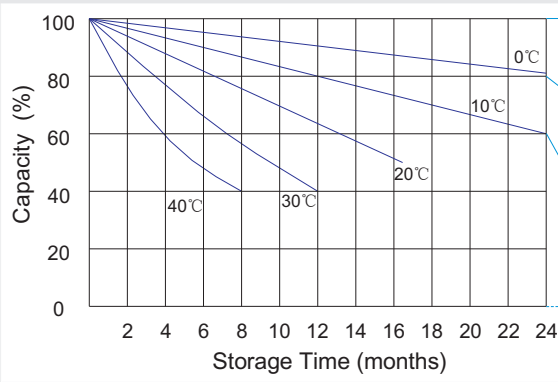

Supplementary charge required (Carry out supplementary charge before use if 100% capacity is required)

Supplementary charge required before use. This supplementary charge will help to recover the capacity and should be made as early as possible.

Supplementary charge may often fail to recover the capacity. The battery should never be left standing till this state is reached

Supplementary charge and storage guidelines

Charge characteristic Curve for standby use

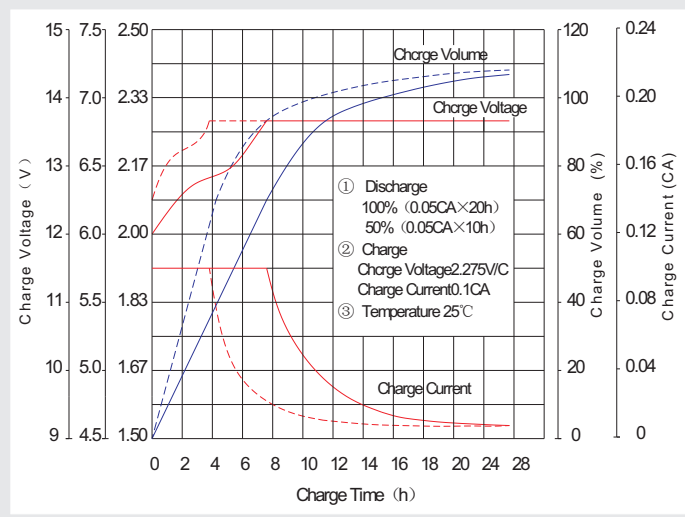

Discharge characteristic Curve

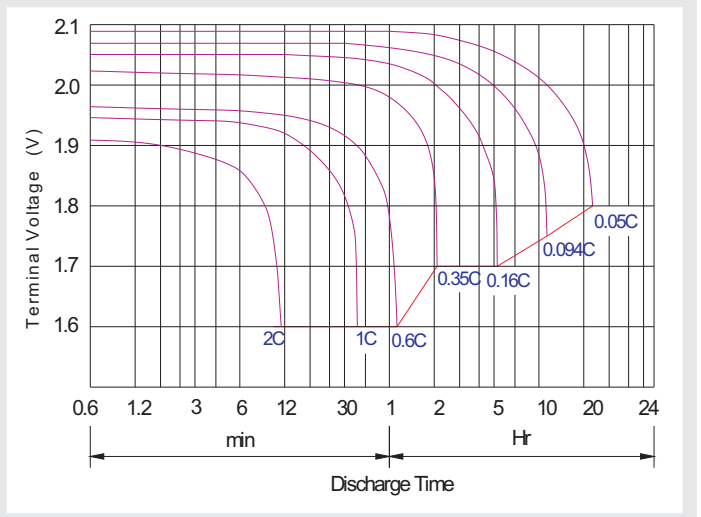

Capacity Factors With Different Temperature

Battery Type		-20°C	-10°C	0°C	5°C	10°C	20°C	25°C	30°C	40°C	45°C
GEL Battery	6V&12V	50%	70%	83%	85%	90%	98%	100%	102%	104%	105%
	2V	60%	75%	85%	88%	92%	99%	100%	103%	105%	106%
AGM Battery	6V&12V	46%	66%	76%	83%	90%	98%	100%	103%	107%	109%
	2V	55%	70%	80%	85%	92%	99%	100%	104%	108%	110%

Discharge Current VS. Discharge Voltage

Final Discharge Voltage V/cell	1.75V	1.70V	1.60V
Discharge Current (A)	(A) ≤ 0.2C	0.2C < (A) < 1.0C	(A) ≥ 1.0C

Maintenance & Cautions

Float Service:
※ Every month, recommend inspection every battery voltage.
※ Every three months, recommend equalization charge for one time.
Equalization charge method:
Discharge: 100% rate capacity discharge.
Charge: Max. current 0.3CA, constant voltage 2.4-2.45V/Cell charge 24h.
※ Effect of temperature on float charge voltage: -3mV/°C/Cell.
※ Length of service life will be directly affected by the number of discharge cycles, depth of discharge, ambient temperature and charging voltage.

Charge the batteries at least once every six months, if they are stored at 25°C.

Charging Method:

Constant Voltage	-0.2Cx2h+2.40~2.45V,24h,Max. Current 0.2CA
Constant Current	-0.2Cx2h+0.1CAx12h
Fast	-0.2Cx2h+0.3CAx4.0h